



PRODUCT SPECIFICATION

FREJA Spotlight 60 deg/15 deg

P/N: 100002 (Beam angle 60°)

P/N: 100003 (Beam angle 15°)



SOLUTION DESCRIPTION

PRODUCT DESCRIPTION

BrainLit FREJA is a powerful yet discreet, tiltable, dynamic, recessed LED spotlight that brings life and contrast to any room. It provides balance to the emotional experience of a space. By dynamically adjusting its color temperature anywhere between cold white (6500K) to warm white (2700K) you can transform the ambience of a room and promote the circadian alignment. BrainLit FREJA embraces the black body curve with exceptional color rendering. It provides 2200lm at full power and dims smoothly down to 0,1%.

AREAS OF USE (examples)

Office	High Value Offices / High Risk Offices / Meetings & Seminar Rooms
Industrial	High Value Manufacturing / High Risk Operations / Control Rooms
Education	Conference Centres / Class Rooms
Hospitality	Customer Interaction Centres / Receptions / Conference Centres / Terminals / Lounges / Premium Room Settings
Residential	Nursing Homes / Elderly Care / Luxury Room Settings

MEASUREMENTS / PACKAGING

Weight (kg)	1,2
Size LxWxH (mm)	NAxNAx125
Diameter (mm)	165
Box quantity	1
Boxed size LxWxH (mm)	210x180x160
Boxed weight (kg)	1,3

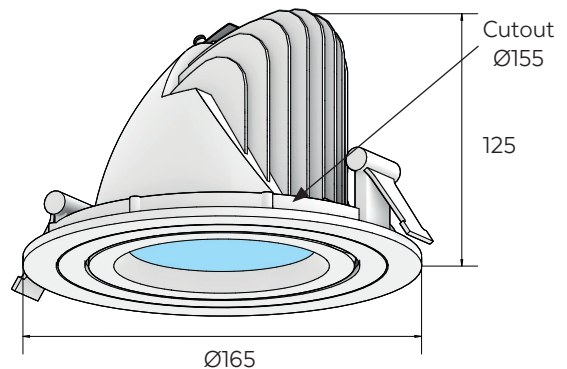

Driver size LxWxH (mm): 154x78x31

MARKET AVAILABILITY

EMEA EU



PRODUCT TECHNICAL SPECIFICATION

LIGHT PROPERTIES

Light source type	LED
LED color temperature	2700K-6500K
Color rendering	CRI/Ra >90
Lumen output	2200lm
mDER range	42%-99%
Beam angle	60° or 15°
Dimming range	0,1% - 100 %
Flicker handling	$P_{st}^{LM} \leq 1$, SVM $\leq 0,4$, IEEE 1789 comp.
Lifetime	0,85 (LLMF 50 000h) >100 000h (L70B50)

POWER PROPERTIES

Rated input power	38 W
Efficacy*	67 lm/W
Supply voltage range	120-250V
Supply power frequency	50/60Hz
Maximum circuit breaker loading (no of luminaires):	B10 B13 B16 C10 C13 C16 @230V 43 56 69 43 56 69
DALI device type	6
DALI-2 compliant	Yes
Power and DALI connector	WAGO WINSTA®. Cable length: 0,5m

MECHANICAL PROPERTIES

Colors	White (RAL 9003)
Material	Die cast aluminum
Configuration	Recessed tiltable spot light
Mounting	Recessed
IP rating	20
Certifications	CE

*At maximum intensity and CCT

This document contains information that is subject to change without notice. This document is solely intended for, and may only be used for, the purpose of providing luminaire products to the BrainLit BioCentric Lighting System. The performance indications for BrainLit products set forth in this document are based on, and conditioned on, the products being used solely in the BrainLit BioCentric Lighting System. However, this document shall not be deemed a product warranty, whether express or implied. The BrainLit product warranty is solely contained in the purchase agreement with each customer. This document is subject to BrainLit AB's copyright. No part of this document may be reproduced or transmitted in any form or by any means, or shared with any third party, without the prior written approval of BrainLit AB. BrainLit products may be protected by one or more patents and by copyright and design rights. "BrainLit" and "BioCentric Lighting" are registered trade marks of BrainLit AB. This document does not confer upon the recipient a license to any of BrainLit intellectual property rights.

TYPICAL CHARACTERIZATION DATA

Light distribution

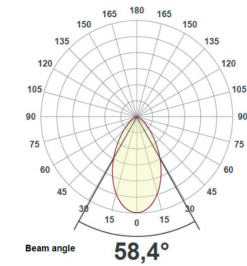

Beam description

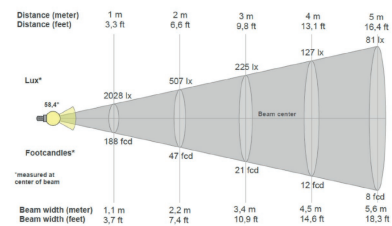

Color rendering TM-30

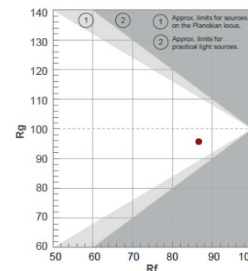

Color rendering CRI, (CIE 1931)

